

MK60DP

A Compact Double Filter Fuel Management System
Perfect For Small to Mid-Size Motors

Engine Reliability Starts With Clean Fuel!

Contaminated fuel is the most common cause of diesel engine shutdown! This issue is even more prevalent with motors that are not frequently used. The simple answer to this problem is to keep your complete fuel system clean, from tank to engine.

Our full feature MK60DP system is an advanced double filter model that offers everything you need to keep your fuel clean and motor running smoothly. A compact design capable of fitting in tight spaces, it does far more than just filter your fuel. It also keeps your entire fuel system clean through a preventative process called "fuel polishing," which removes contaminants, water and impurities before they are ingested into the engine. It's double filter functionality also allows you to switch filters on the fly without stopping the motors.

The MK60DP includes a remote warning panel to alert you about any potential problems, as well as an integrated fuel pumps for bleeding, priming and backup of the main engine fuel pump. It also uses commonly available Racor® filters, so you know you should be able to find a new one no matter where you are in the world.

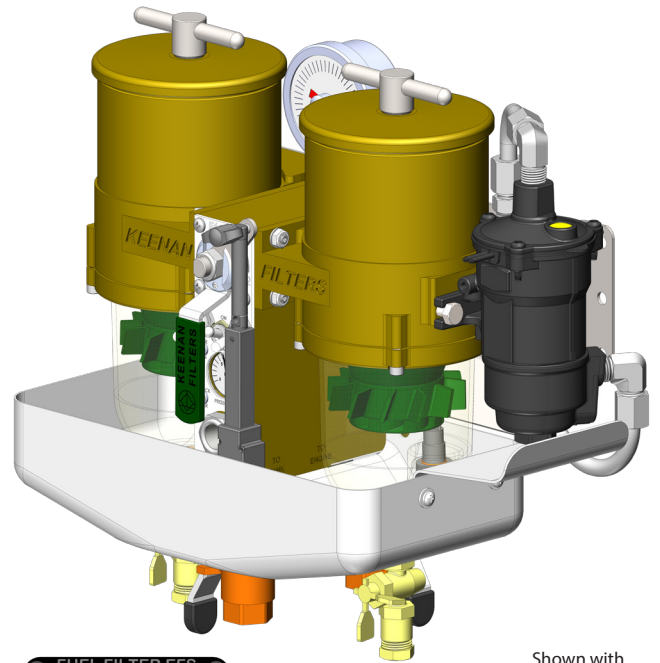

Shown with
Optional EFS System

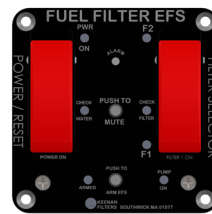

System Features

- Dual filter design allows for filter switching and replacement without stopping motor(s).
- Fuel polishing ensure clean fuel delivery, no matter the source, for reduced maintenance costs.
- Remote warning panel alerts operator of problems before they get to the motor and can be installed in any location convenient for the operator. Advance warning also allows for use of finer micron filter.
- Optional EFS system allows for remote manual, or automatic, filter changes from warning panel.
- Separate fuel pump can be used as back-up if main motor pumps fail.
- System testing allows operator to verify fuel system integrity before operation or after maintenance.
- Uses widely available genuine Racor® elements.
- Machined from high quality aluminum & stainless.



Tests



Saves



Cleans



Primes



Warns

Is Your Fuel Keenan Clean?



**KEENAN
FILTERS®**
By KTI Systems, Inc.

MK60DP

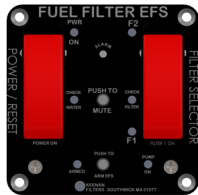
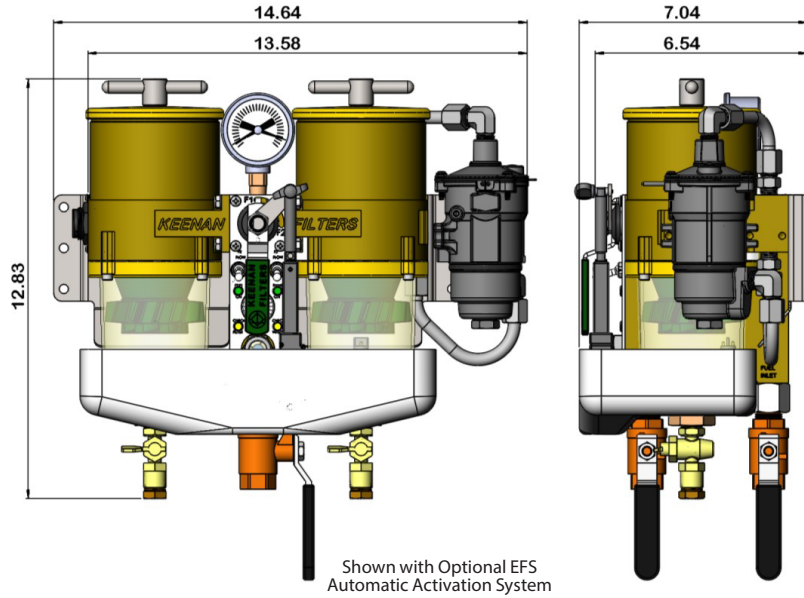

KP600 Remote Warning Panel



K6060 Interface Box

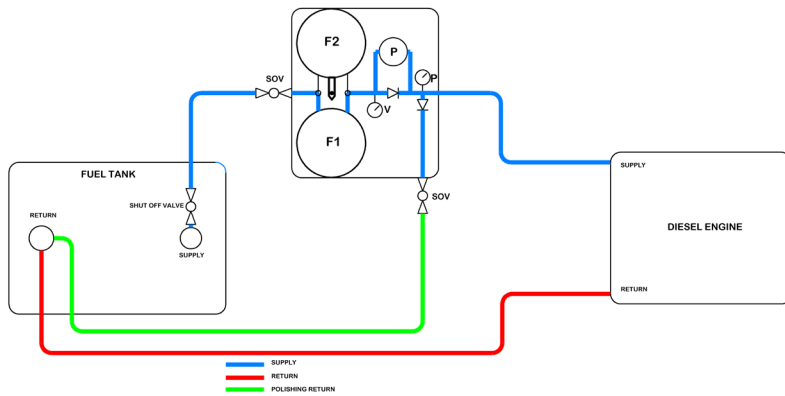

MK60DP Specifications

Height	12.83" (32.5 cm)
Width	14.64" (37 cm) filter 12.75" (32.3 cm) mount panel
Depth	7.04" (17.9 cm)
Service Clearance	5" (12.7 cm) above 2" (5.1 cm) below
Weight	19.2lbs (8.7 kg)
Inlet and out ports	#10 Orb 7/8-14 or 1/2" NPT adapter (standard)
Fuel	Diesel
Filter Max Fuel Flow	60 gph (227 lt/h)
Design Pressure	30 psi (2.1 bar)
Max Operating Pressure	35 psi (2.4 bar)
Normal Operating Vacuum	0-6 in Hg (20 kPa)
Vacuum Alarm	8" + 2" in Hg (27 + 7 kPa)
Bowl Water Alarm Capacity	5.5 oz. (163 ml)
Water Removal	99%
Voltage	12 VDC
Current Draw - Pump on	2.3 amps max
Design Temperature	-40F to 194F
Circuit Protection	5 amp
Pump	Walbro FRB13-2
Psi Flow	6.0 to 8.0 psi (.41 - .55 bar) 60gph (227 lt/hr)
Recommended Replacement elements -Racor®	2 micron 2010SM-OR 10 micron 2010TM-OR 30 micron 2010PM-OR



Most Diesel Engine Failures Start In The Fuel Tank

Diesel Fuel is unstable by nature, solids begin to form and the sludge that accumulates can eventually clog your diesel filters, ruin your injectors causing your engine to stop. Every engine runs better with a system that cleans fuel, removes water, tests for leaks, and senses when it's time for service. KEENAN FILTERS are the most efficient and most reliable fuel maintenance system you can install.



**KEENAN
FILTERS®**
By KTI Systems, Inc.

www.keenanfilters.com

KTI Systems, Inc.
55 Hudson Drive, Southwick, MA 01077
1-800-336-0315 | 413-569-3323