

MK1500 DP

High Capacity Primary Fuel Filter & Polishing System Provides Up To 1500 GPH of Clean Fuel

Our largest system, the new MK1500DP is the professional, dual filter solution for large boat fuel filtering and stored fuel polishing. With up to 1500 gallons per hour capacity, it ensures clean fuel delivery for reliable, non-stop engine operation. Its patent pending, top-load filter design simplifies messy filter replacement without stopping the motors. Utilizing readily available FBO filters, it removes impurities, emulsified water, and water droplets, while increasing the service life. The system also includes our EFS warning & control panel that can be remotely located in the bridge or cockpit so the captain can be alerted to potential issues and switch filters with the flick of a switch from the helm. It can also be set to switch automatically.

Features & Benefits:

- Allows filter replacement without stopping motors.
- Removes emulsified water that destroys injectors.
- Top loading filter elements for quick & efficient replacement.
- Fuel polishing routinely cleans contaminants from stored fuel for clean, dry fuel delivery.
- Internal fuel passages & fill pump for internal priming & servicing.
- Electric Filter Switch (EFS) allows operator to switch filters from the remote warning panel when the filter starts to clog or water is detected.
- Advance warning allows operator to use a lower micron pre-filter for overall cleaner engine fuel delivery.
- Early filter clog & water detection limits potential inadvertent engine shut down.
- System allows the operator to test the system for indication and integrity before operation, or after maintenance has been performed.
- Uses readily available FBO filters.

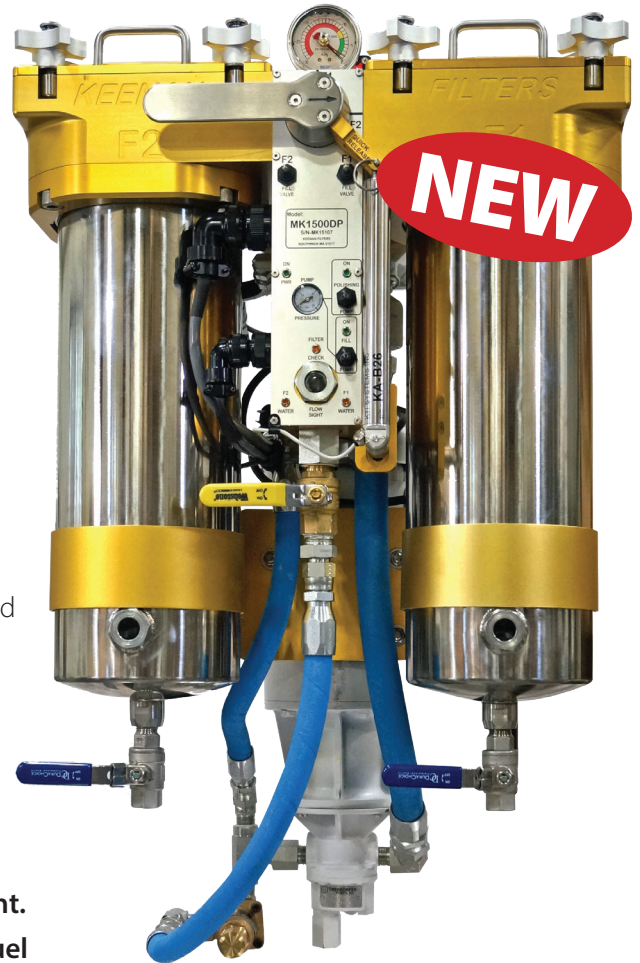

Exclusive Features of the MK1500DP

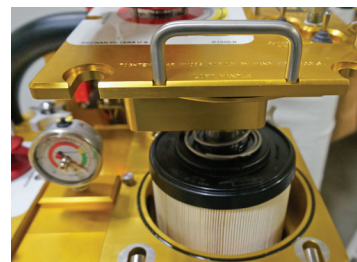

Patented Top Loading Filter Design
Allows for Quick, Clean Replacement

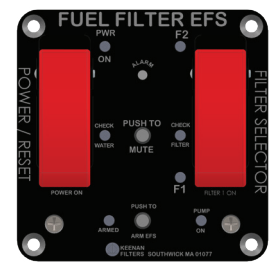

Remote Warning Panel
With Alarm Mute
(Shown with optional EFS)

[Complete Specs on Reverse Side](#)

Single & Dual Filter Models
Ranging from 60 to 1500 GPH Available

Made in the USA

Is Your Fuel Keenan Clean?



**KEENAN
FILTERS®**

By KTI Systems, Inc.

MK1500 DP Specifications

Engine Room Mounted Dimensions:

Height (including top plug): 41"
 Width..... 22"
 Depth: 22"

Stand-Alone Mount Dimensions:

Height (including top plug): 41"
 Width..... 28.64"
 Depth: 27"

General Specifications:

Service Clearance..... 14" Above | 4" Below
 Weight: 160 lbs
 Inlet Ports..... #24 J1926 ORB
 Out Ports NPT 6405 adapter
 Fuel..... Diesel
 Max Flow 1500 Gallons Per Hour
 Operating Pressure 40psi / 50 psi max
 Normal Operating Vacuum 0-6 in HG
 Vacuum Alarm 8" ± 2" in Hg
 Bowl Water Capacity 50 oz
 Water Removal 99%
 Voltage 12 VDC
 Filter Specs FBO - 10 micron
 Ambient Temperature Range..... - 40 to 194 F

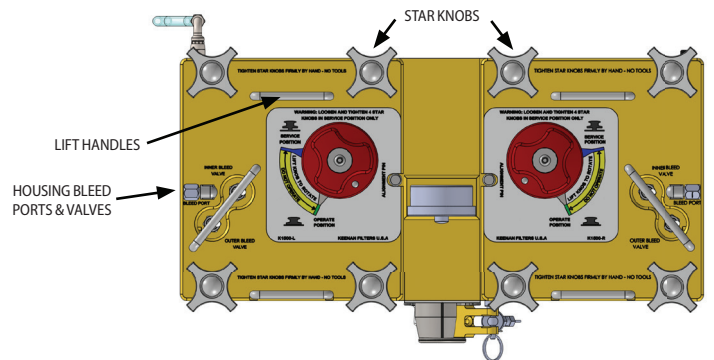
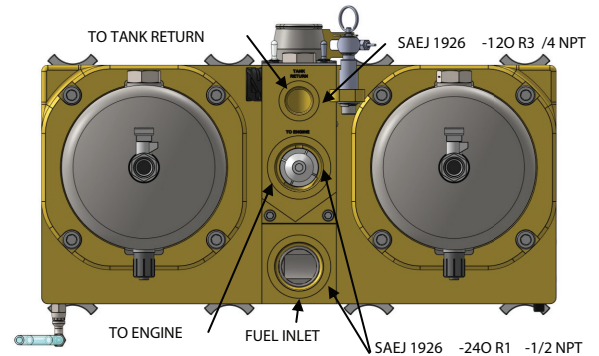
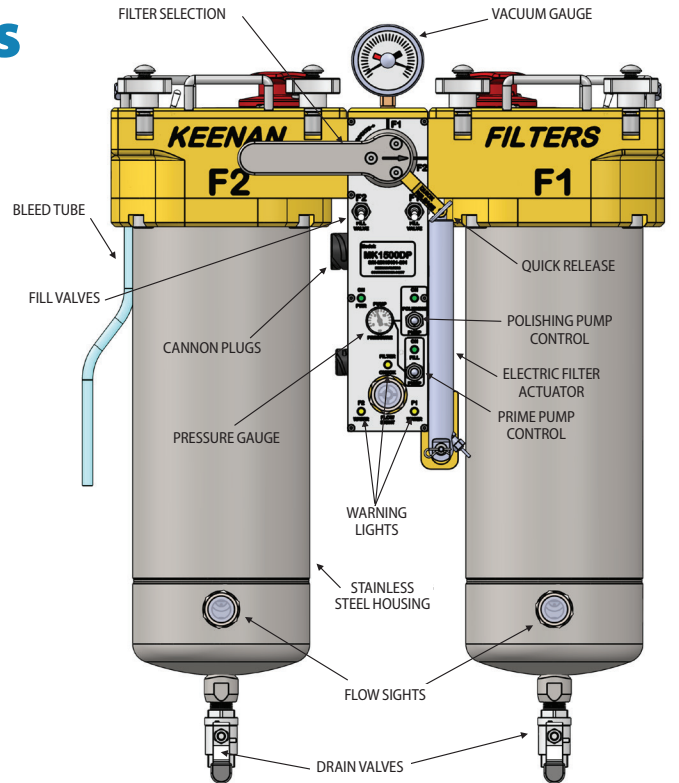

MK1500 DP Features



**Built-in K7240
Remote/Phone
Interface Module
(Included)**

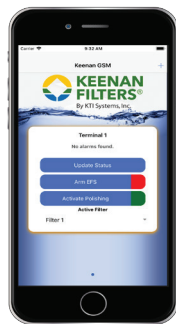

**Smart Phone Control
(Optional)**

**Thinking About an Upgrade?
Please Contact Us With Any Fuel Questions**

800.336.0315 | www.ktisystems.com

Made in the USA

Is Your Fuel Keenan Clean?



**KEENAN
FILTERS®**

By KTI Systems, Inc.